

High Voltage, Low Power LDO

DESCRIPTION

The SUM3559A is a high voltage, low power consumption and high performance LDO. The family uses an advanced CMOS process and a PMOSFET pass device to achieve fast start-up, with high output voltage accuracy. The SUM3559A is stable with a 1.0 μF ~ 10 μF ceramic output capacitor, and uses a precision voltage reference and feedback loop to achieve a worst-case accuracy of 1% over all load, line, process, and temperature variations.

FEATURES

- Wide Input Voltage Range: up to 45 V
- Output Current: 350 mA
- Standard Fixed Output Voltage Options: 3.3 V, 5.0 V
- Other Output Voltage Options Available on Request
- Low I_{Q} : 2.6 μA
- Low Dropout Voltage
- Short current protection: 150 mA
- Excellent Load/Line Transient Response
- Line Regulation: 0.01%/V typical
- Package: SOT89-3

ORDER INFORMATION

Model	Package	Ordering Number	Packing Option
SUM3559A	SOT89-3	SUM3559A-33P	Tape and Reel, 1000
	SOT89-3 (L-Type)	SUM3559A-33PL	Tape and Reel, 1000
	SOT89-3	SUM3559A-50P	Tape and Reel, 1000
	SOT89-3 (L-Type)	SUM3559A-50PL	Tape and Reel, 1000

PIN CONFIGURATION (Top View)

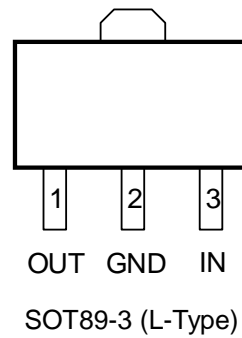
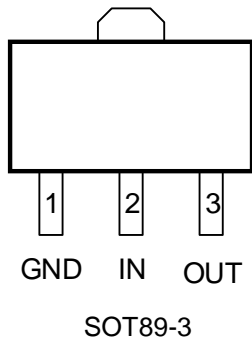

PIN DESCRIPTIONS

Pin		Symbol	Description
SOT89-3	SOT89-3 (L-Type)		
1	2	GND	Ground.
2	3	IN	Supply input pin.
3	1	OUT	Output pin.

BLOCK DIAGRAM

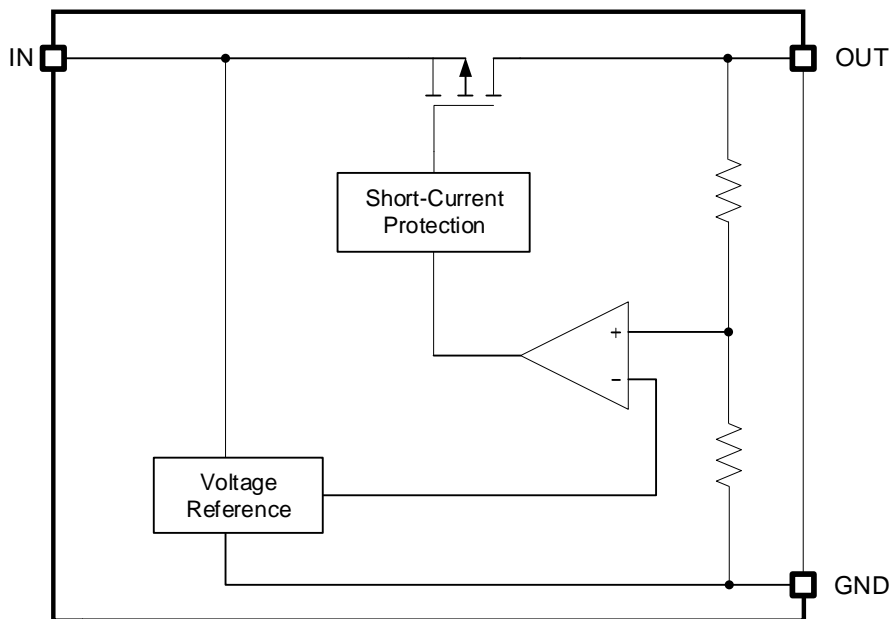

FUNCTIONAL DESCRIPTION

Input Capacitor

A 1 μF ~ 10 μF ceramic capacitor is recommended to connect between V_{IN} and GND pins to decouple input power supply glitch and noise. The amount of the capacitance may be increased without limit. This input capacitor must be located as close as possible to the device to assure input stability and less noise. For PCB layout, a wide copper trace is required for both V_{IN} and GND.

Output Capacitor

An output capacitor is required for the stability of the LDO. The recommended output capacitance is from 1 μF to 10 μF , Equivalent Series Resistance (ESR) is from 5 m Ω to 100 m Ω , and temperature characteristics are X7R or X5R. Higher capacitance values help to improve load / line transient response. The output capacitance may be increased to keep low undershoot / overshoot. Place output capacitor as close as possible to OUT and GND pins.

Low Quiescent Current

The SUM3559A, consuming only around 2.6 μA for all input range and output loading, provides great power saving in portable and low power applications.

Short Current Limit Protection

When output current at the OUT pin is higher than current limit threshold or the OUT pin is short-circuit to GND, the short current limit protection will be triggered and clamp the output current to approximately 100 mA to prevent over-current and to protect the regulator from damage due to overheating.

RECOMMENDED OPERATING CONDITIONS

Parameter	Rating	Unit
Operating Temperature Range	-40 to +85	°C

ABSOLUTE MAXIMUM RATINGS

Parameter	Rating	Unit
IN pin to GND pin	-0.3 to 48	V
OUT pin to GND pin	-0.3 to 6	V
Thermal Resistance (Junction to Ambient)	135	°C/W
Junction Temperature	150	°C
Storage Temperature	-65 to 150	°C
Lead Temperature (Soldering, 10 sec)	300	°C
ESD (HBM mode), ESDA/JEDEC JS-001-2017	±2000	V

NOTE:

Stresses beyond those listed under “ABSOLUTE MAXIMUM RATINGS” may cause permanent damage to the device. These are stress ratings only, and functional operation of the device at these or any other conditions beyond those indicated in the operational sections of the specifications is not implied. Exposure to absolute maximum rating conditions for extended periods may affect device reliability.

CAUTION

This integrated circuit can be damaged by ESD if you don't pay attention to ESD protection. SUMSEMI recommends that all integrated circuits be handled with appropriate precautions. Failure to observe proper handling and installation procedures can cause damage. ESD damage can range from subtle performance degradation to complete device failure. Precision integrated circuits may be more susceptible to damage because very small parametric changes could cause the device not to meet its published specifications. SUMSEMI reserves the right to make any change in circuit design, specification or other related things if necessary without notice at any time. Please contact SUMSEMI sales office to get the latest datasheet.

ELECTRICAL CHARACTERISTICS

$V_{IN} = V_{OUT} + 2\text{ V}$; $I_{OUT} = 10\text{ mA}$, $C_{IN} = C_{OUT} = 1.0\text{ }\mu\text{F}$, unless otherwise noted. Typical values are at $T_A = +25^\circ\text{C}$.

Parameter	Symbol	Test Conditions	Min	Typ	Max	Unit
Operating Input Voltage	V_{IN}				45	V
Regulated Output Voltage	V_{OUT}		$V_{OUT} \times 0.99$		$V_{OUT} \times 1.01$	V
Line Regulation	Reg_{LINE}	$2.5\text{ V} \leq V_{IN} \leq 36\text{ V}$, $I_{OUT} = 10\text{ mA}$		0.01	0.04	%/V
Dropout Voltage	V_{DROP}	$V_{OUT} = 3.3\text{ V}$, $I_{OUT} = 100\text{ mA}$		330		mV
		$V_{OUT} = 3.3\text{ V}$, $I_{OUT} = 200\text{ mA}$		690		
Load Regulation	Reg_{LOAD}	$1\text{ mA} \leq I_{OUT} \leq 300\text{ mA}$, $V_{IN} = V_{OUT} + 2\text{ V}$			40	mV
Maximum Output Current	I_{OUT}	$V_{IN} = V_{OUT} + 2\text{ V}$	350			mA
Quiescent Current	I_Q	$I_{OUT} = 0\text{ mA}$		2.6	4	μA
Power Supply Rejection Ratio	PSRR	$V_{IN} = V_{OUT} + 1\text{ V}$, $I_{OUT} = 20\text{ mA}$, $f = 1\text{ kHz}$		60		dB
Output Noise Voltage	e_N	$V_{IN} = V_{OUT} + 2\text{ V}$, $I_{OUT} = 1\text{ mA}$, $f = 10\text{ Hz to } 100\text{ kHz}$, $V_{OUT} = 3.3\text{ V}$, $C_{OUT} = 1\text{ }\mu\text{F}$		100		μVrms
Thermal Shutdown Temperature	T_{SD}	Temperature Increasing from $T_A = +25^\circ\text{C}$		155		$^\circ\text{C}$
Thermal Shutdown Hysteresis	T_{SDH}	Temperature Falling from T_{SD}		20		$^\circ\text{C}$

TYPICAL PERFORMANCE CHARACTERISTICS

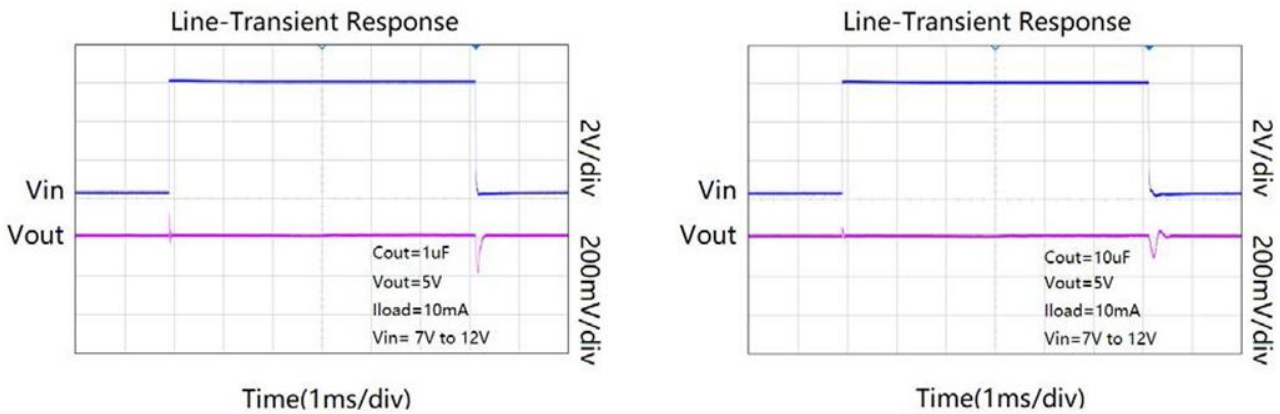

Figure 1. Line-Transient Response

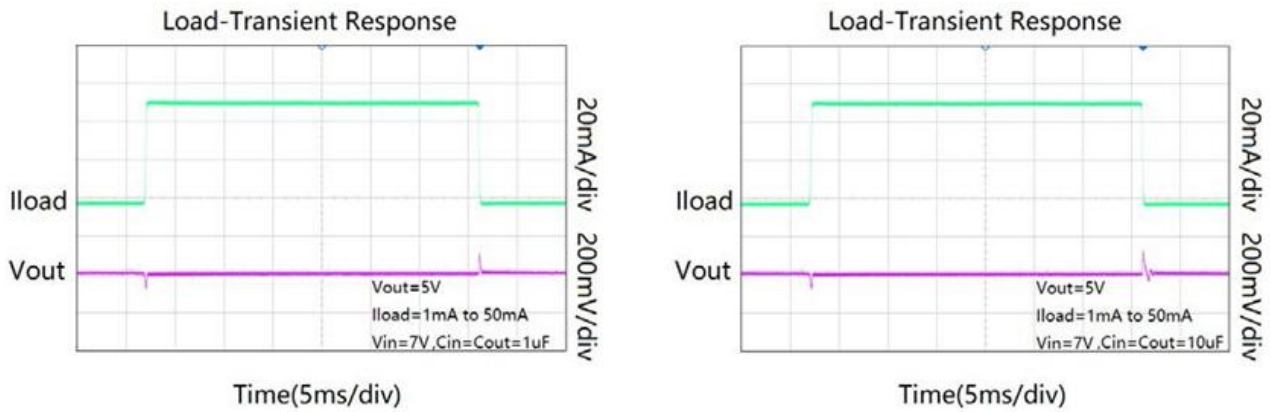

Figure 2. Load-Transient Response

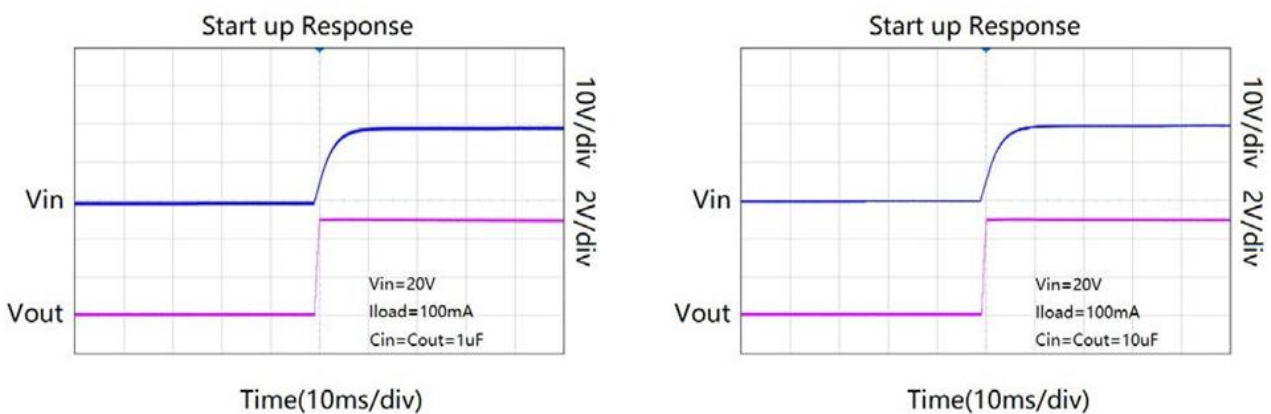

Figure 3. Start up Response

TYPICAL PERFORMANCE CHARACTERISTICS (continued)

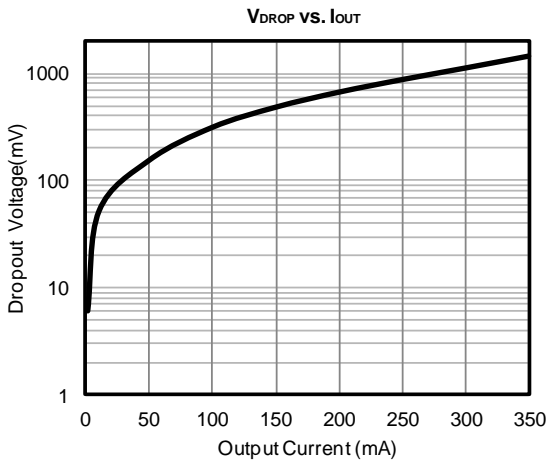

Figure 4. Dropout Voltage vs. Output Current

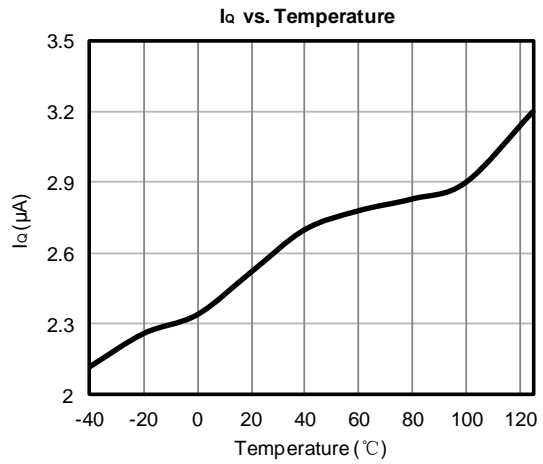
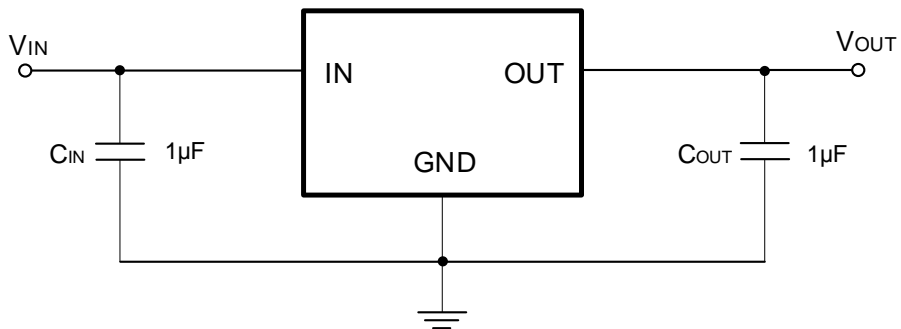
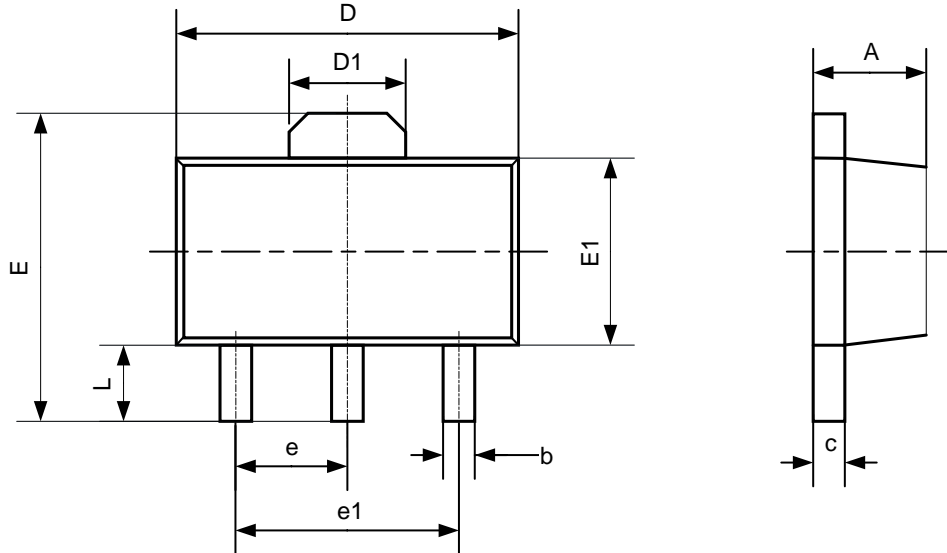

Figure 5. I_Q vs. Temperature

APPLICATION CIRCUITS



PACKAGE OUTLINE
SOT89-3

Symbol	Dimensions In Millimeters	
	Min	Max
A	1.400	1.600
b	0.320	0.520
c	0.350	0.440
D	4.400	4.600
D1	1.550REF	
E	3.940	4.250
E1	2.300	2.600
e	1.500BSC	
e1	3.000BSC	
L	0.900	1.200