

Ultra-Low I_q 300mA CMOS LDO Regulator

DESCRIPTION

The SUM3636 series of CMOS low dropout regulators are designed specifically for portable battery-powered applications which require ultra-low quiescent current. The ultra-low consumption of type 0.8 μ A ensures long battery life and dynamic transient boost feature improves device transient response for wireless communication applications.

The device is available in SOT-23 package.

FEATURES

- Operating Input Voltage Range: 2.0 V to 5.5 V
- Output Voltage Range: 1.2 V, 1.5 V, 1.8 V, 2.5 V, 2.8 V, 3.0 V, 3.3 V, 3.6 V
- Ultra-Low Quiescent Current Typical 0.8 μ A
- Low Dropout: 170 mV Typ. at 150 mA @ V_{OUT} = 3.3 V
- High Output Voltage Accuracy $\pm 1.5\%$
- Stable with Ceramic Capacitors 1 μ F
- Over-Current Protection
- Thermal Shutdown Protection
- With auto discharge function at off state

APPLICATIONS

- Battery Powered Equipments
- Portable Communication Equipments
- Cameras, Image Sensors and Camcorders
- Label Information

ORDER INFORMATION

Model	Package	Ordering Number	Packing Option
SUM3636	SOT-23	SUM3636-XXK	Tape and Reel, 3000

*XX: When expressed as 18, the output voltage is 1.8 V; when expressed as 30 the output voltage is 3.0 V.

PIN CONFIGURATION (Top View)

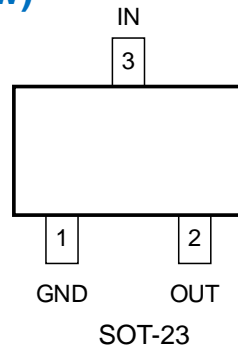

PIN DESCRIPTIONS

Pin	Symbol	Description
SOT-23		
1	GND	Ground.
2	OUT	Output Pin.
3	IN	Power Supply Input Voltage.

ABSOLUTE MAXIMUM RATINGS⁽²⁾

Parameter	Symbol	Value	Unit	
Input Voltage	V_{IN}	6.5	V	
Output Voltage	V_{OUT}	-0.3 to $V_{IN} + 0.3$	V	
Junction Temperature	T_J	150	°C	
Storage Temperature	T_{STG}	-65 to 150	°C	
Thermal Characteristics, Thermal Resistance, Junction-to-Air ⁽¹⁾	$R_{\theta JA}$	SOT23-3	357	°C/W
Human Body Model	ESD	6000	V	
ESD Capability		2000	V	
Current Maximum Rating	Latch up	200	mA	

NOTE:

- (1) This particular frame decreases the total thermal resistance of the package and increases its ability to dissipate power when an appropriate area of copper on the printed circuit board is available for heat-sinking.
- (2) Stresses beyond those listed under “ABSOLUTE MAXIMUM RATINGS” may cause permanent damage to the device. These are stress ratings only, and functional operation of the device at these or any other conditions beyond those indicated in the operational sections of the specifications is not implied. Exposure to absolute maximum rating conditions for extended periods may affect device reliability.

CAUTION

This integrated circuit can be damaged by ESD if you don't pay attention to ESD protection. SUMSEMI recommends that all integrated circuits be handled with appropriate precautions. Failure to observe proper handling and installation procedures can cause damage. ESD damage can range from subtle performance degradation to complete device failure. Precision integrated circuits may be more susceptible to damage because very small parametric changes could cause the device not to meet its published specifications.

SUMSEMI reserves the right to make any change in circuit design, specification or other related things if necessary without notice at any time. Please contact SUMSEMI sales office to get the latest datasheet.

RECOMMENDED OPERATING CONDITIONS

Symbol	Item	Rating	Unit
V_{IN}	Input Voltage	2.0 to 5.5	V
I_{OUT}	Output Current	0 to 300	mA
T_A	Operating Ambient Temperature	-40 to 85	°C
C_{IN}	Effective Input Ceramic Capacitor Value	0.47 to 4.7	μF
C_{OUT}	Effective Output Ceramic Capacitor Value	0.47 to 4.7	μF

ELECTRICAL CHARACTERISTICS

$V_{IN} = 2.5\text{ V}$, $I_{OUT} = 1\text{ mA}$, $C_{IN} = 1\text{ μF}$, $C_{OUT} = 1\text{ μF}$, $T_A = +25\text{ °C}$, unless otherwise noted.

Symbol	Parameter	Test Conditions	Min	Typ	Max	Unit
V_{IN}	Operating Input		2.0		5.5	V
V_{OUT}	Output Voltage	$T_A = +25\text{ °C}$	-1.5		+1.5	%
		$-40\text{ °C} \leq T_A \leq 85\text{ °C}$	-2.5		+2.5	
I_Q	Quiescent Current	$I_{OUT} = 0\text{ mA}$		0.8	1.1	μA
LineReg	Line Regulation	$2.5\text{ V} \leq V_{IN} \leq 5.5\text{ V}$, $I_{OUT} = 1\text{ mA}$		0.1	0.2	%/V
LoadReg	Load Regulation	$1\text{ mA} \leq I_{OUT} \leq 150\text{ mA}$, $V_{IN} = 2.5\text{ V}$		20		mV
V_{DROP}	Dropout Voltage	$I_{OUT} = 150\text{ mA}$, $V_{OUT} = 3.3\text{ V}$		170		mV
I_{LMT}	Current Limit			300	550	mA
I_{SHORT}	Short Circuit Current	$V_{OUT} = 0\text{ V}$		90		mA
PSRR	Power supply Rejection Ratio	$I_{OUT} = 100\text{ mA}$	$f = 1\text{ kHz}$		-55	dB
			$f = 10\text{ kHz}$		-52	
e_N	Output Noise Voltage	$V_{IN} = 2.5\text{ V}$, $I_{OUT} = 1\text{ mA}$, $f = 10\text{ Hz to }100\text{ kHz}$, $C_{OUT} = 1\text{ μF}$		100		μV _{RMS}

APPLICATION CIRCUITS

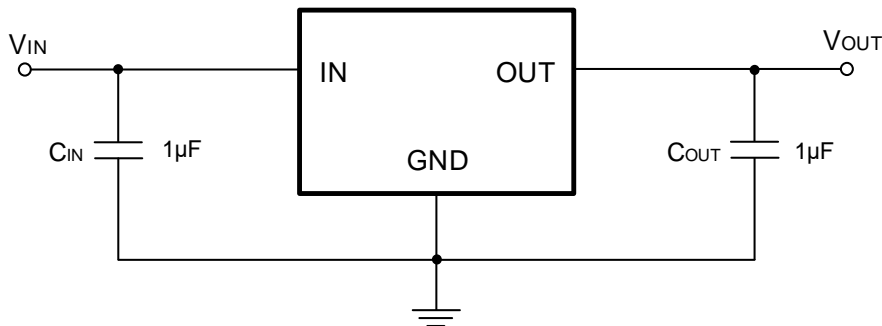

APPLICATIONS INFORMATION

General

The SUM3636 is a high performance 300 mA Linear Regulator with Ultra Low I_Q . This device delivers low Noise and high Power Supply Rejection Ratio with excellent dynamic performance due to employing the Dynamic Quiescent Current adjustment which assure ultra low I_Q consumption at no-load state. These parameters make this device very suitable for various battery powered applications.

Input Decoupling (C_{IN})

It is recommended to connect at least a 1 μ F Ceramic X5R or X7R capacitor between IN and GND pins of the device. This capacitor will provide a low impedance path for any unwanted AC signals or Noise superimposed onto constant Input Voltage. The good input capacitor will limit the influence of input trace inductances and source resistance during sudden load current changes.

Higher capacitance and lower ESR Capacitors will improve the overall line transient response.

Output Decoupling (C_{OUT})

The SUM3636 does not require a minimum Equivalent Series Resistance (ESR) for the output capacitor. The X5R and X7R types have the lowest capacitance variations over temperature thus they are recommended. There is recommended connect the output capacitor as close as possible to the output pin of the regulator.

Current Limit Protection

When output current at the OUT pin is higher than current limit threshold, the current limit protection will be triggered and clamp the output current to approximately 550 mA to prevent over-current and to protect the regulator from damage due to overheating.

Thermal Shutdown

When the die temperature exceeds the Thermal Shutdown point ($T_{SD} = 160^\circ\text{C}$ typical) the device goes to disabled state and the output voltage is not delivered until the die temperature decreases to 150°C . The Thermal Shutdown feature provides a protection from a catastrophic device failure at accidental overheating. This protection is not intended to be used as a substitute for proper heat sinking.

Power Dissipation and Heat sinking

The maximum power dissipation supported by the device is dependent upon board design and layout. Mounting pad configuration on the PCB, the board material and the ambient temperature affect the rate of junction temperature rise for the part. The maximum power dissipation the SUM3636 device can handle is given by:

$$P_{D(MAX)} = \frac{[T_{J(MAX)} - T_A]}{R_{\theta JA}} \quad (\text{eq.1})$$

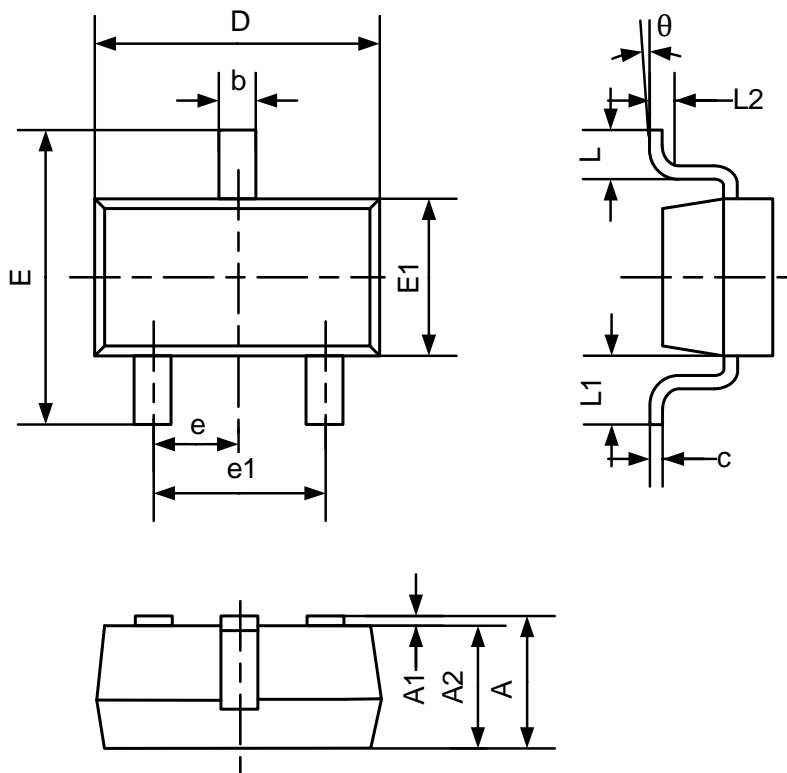
PACKAGE OUTLINE
SOT-23

Symbol	Dimensions In Millimeters	
	Min	Max
A	0.900	1.150
A1	0.000	0.100
A2	0.900	1.050
b	0.300	0.500
c	0.080	0.150
D	2.800	3.000
E	2.250	2.550
E1	1.200	1.400
e	0.950 REF.	
e1	1.800	2.000
L	0.550 REF	
L1	0.300	0.500
θ	0°	8°

V 1.7